

SR4114 - KR4114

PORTAPACCO SPECIFICO - SPECIFIC HOLDER - PORTE-PAQUET SPÉCIFIQUE - SPEZIFISCHER TRÄGER - PORTA-EQUIPAJE ESPECÍFICO - TRANSPORTADOR ESPECÍFICO

KAWASAKI VERSYS 650 (2015)

N°	Descrizione	Caratteristiche	Codice	Quantità
1	Supporto - Support - Support Halterung - Soporte - Apoio	-	GL2839 (dx - sx)	2
2	Vite - Screw Vis - Schraube Tornillo - Parafuso	TEF M8x16	816TEF	4
3	Rondella - Washer - Rondelle Scheibe - Arandela - Arruela	Ø 20 Foro 6mm	620RON	4
4	Vite - Screw Vis - Schraube Tornillo - Parafuso	TSP M6x25	625TSP	2
5	Particolari Inclusi Nel Kit Viteria Della Piastra Components Included In The Fitting Kit Of The Plate Pièces Inclues Dans Le Kit De Vis De La Platine Die Einzelnen Teile Sind Bei Montagekit Der Platte Enthalten Despieces Incluidos En El Kit De Anclajes De La Parrilla	-	-	-

SR4114 - KR4114

PORTAPACCO SPECIFICO - SPECIFIC HOLDER - PORTE-PAQUET SPÉCIFIQUE - SPEZIFISCHER TRÄGER - PORTA-EQUIPAJE ESPECÍFICO - TRANSPORTADOR ESPECÍFICO

KAWASAKI VERSYS 650 (2015)

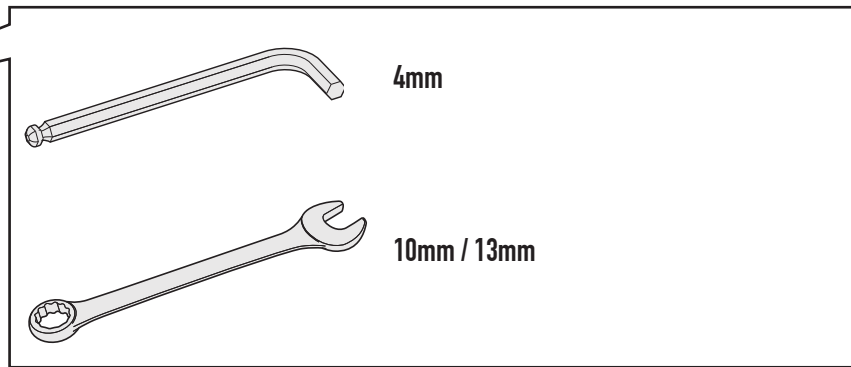
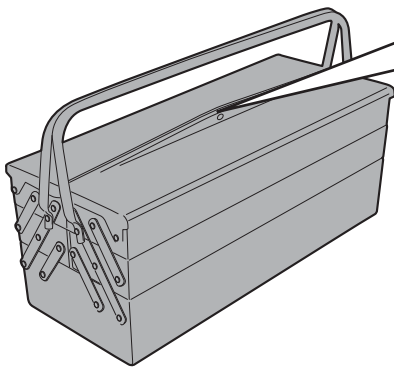
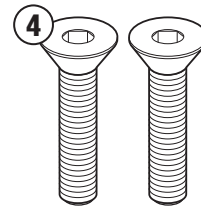
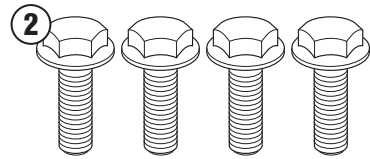
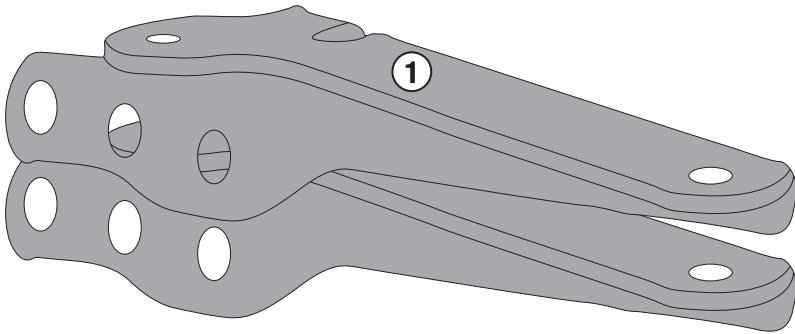

SR4114 - KR4114

PORTAPACCO SPECIFICO - SPECIFIC HOLDER - PORTE-PAQUET SPÉCIFIQUE - SPEZIFISCHER TRÄGER - PORTA-EQUIPAJE ESPECÍFICO - TRANSPORTADOR ESPECÍFICO

KAWASAKI VERSYS 650 (2015)

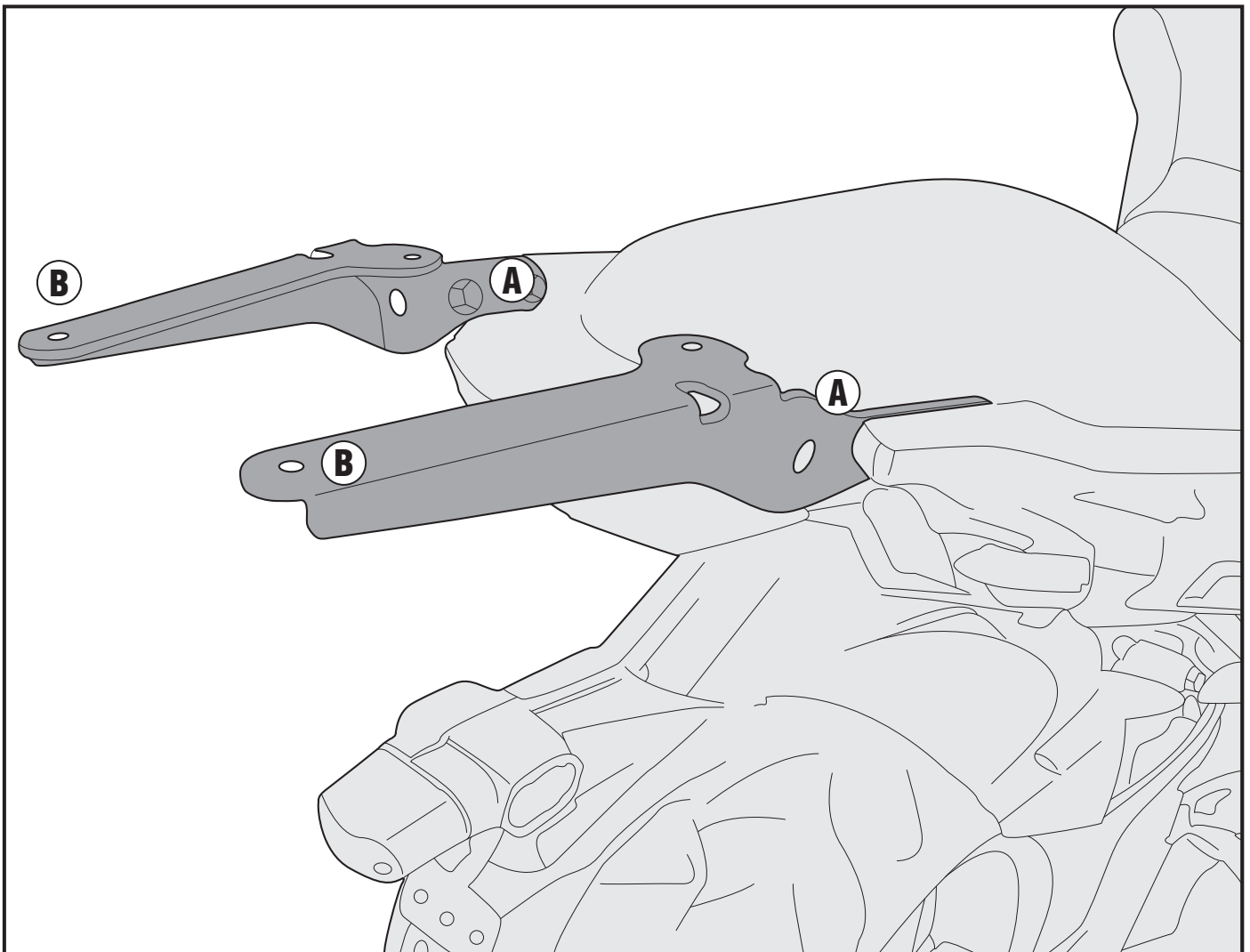

SR4114 - KR4114

PORTAPACCO SPECIFICO - SPECIFIC HOLDER - PORTE-PAQUET SPÉCIFIQUE - SPEZIFISCHER TRÄGER - PORTA-EQUIPAJE ESPECÍFICO - TRANSPORTADOR ESPECÍFICO

KAWASAKI VERSYS 650 (2015)

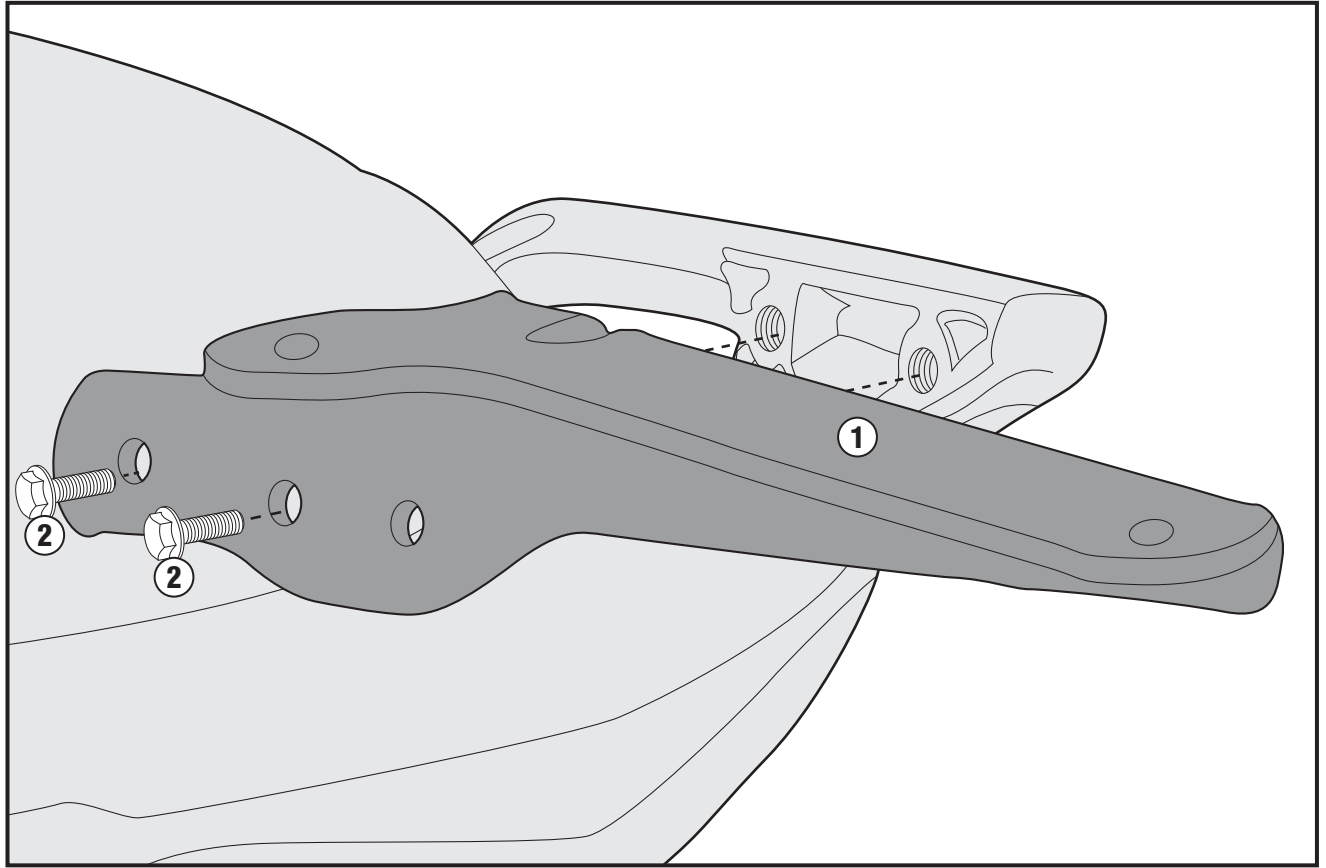

A

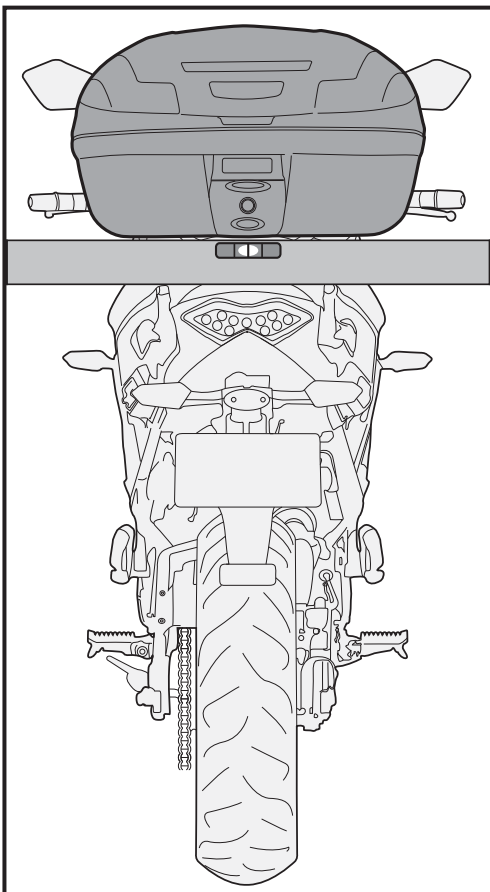

ATTENZIONE:

Terminato il montaggio verificare che la piastra e, quindi, il bauletto risultino perfettamente orizzontali. In caso contrario, compensare l'inclinazione aggiungendo 4 rondelle (particolare n°4) come indicato nella figura B.

WARNING:

Once you have finished the coupling, check that the plate is fully horizontal, if not add the 4 washers (item n°4), as shown in picture B, to readjust the difference.

ACHTUNG:

Am Ende der Montage prüfen Sie, dass sich die Platte und daher der Koffer in einer perfekten horizontalen Position befinden. Andernfalls gleichen Sie die Neigung durch Einfügen von 4 Scheiben aus (Position Nr. 4) wie in den Bilder B gezeigt.

SR4114 - KR4114

PORTAPACCO SPECIFICO - SPECIFIC HOLDER - PORTE-PAQUET SPÉCIFIQUE - SPEZIFISCHER TRÄGER - PORTA-EQUIPAJE ESPECÍFICO - TRANSPORTADOR ESPECÍFICO

KAWASAKI VERSYS 650 (2015)

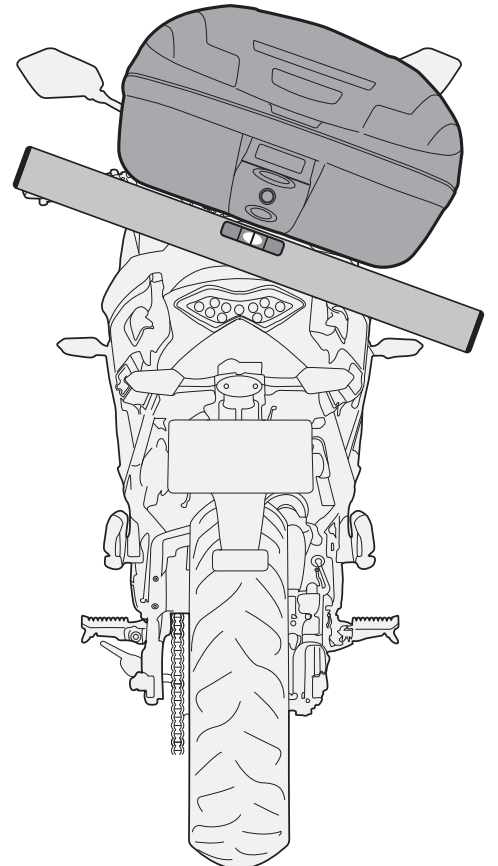
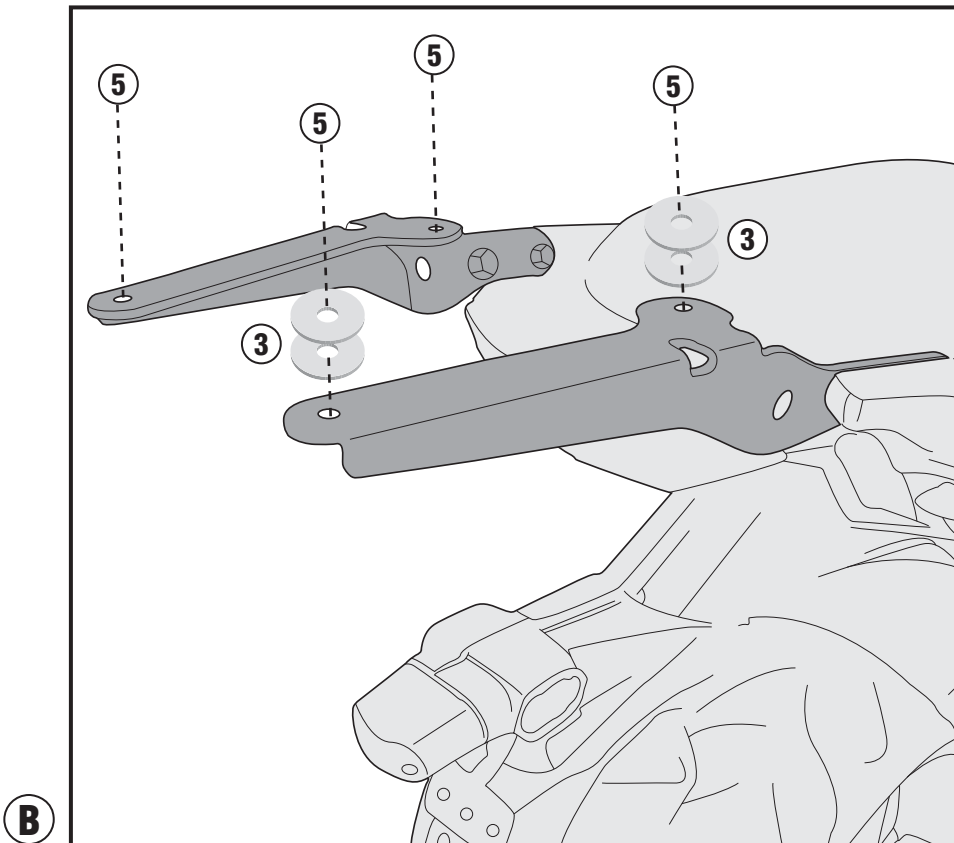
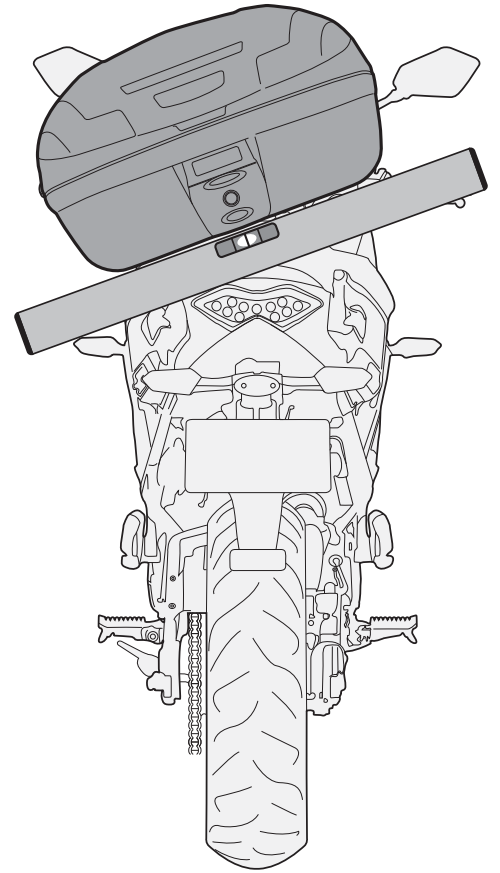
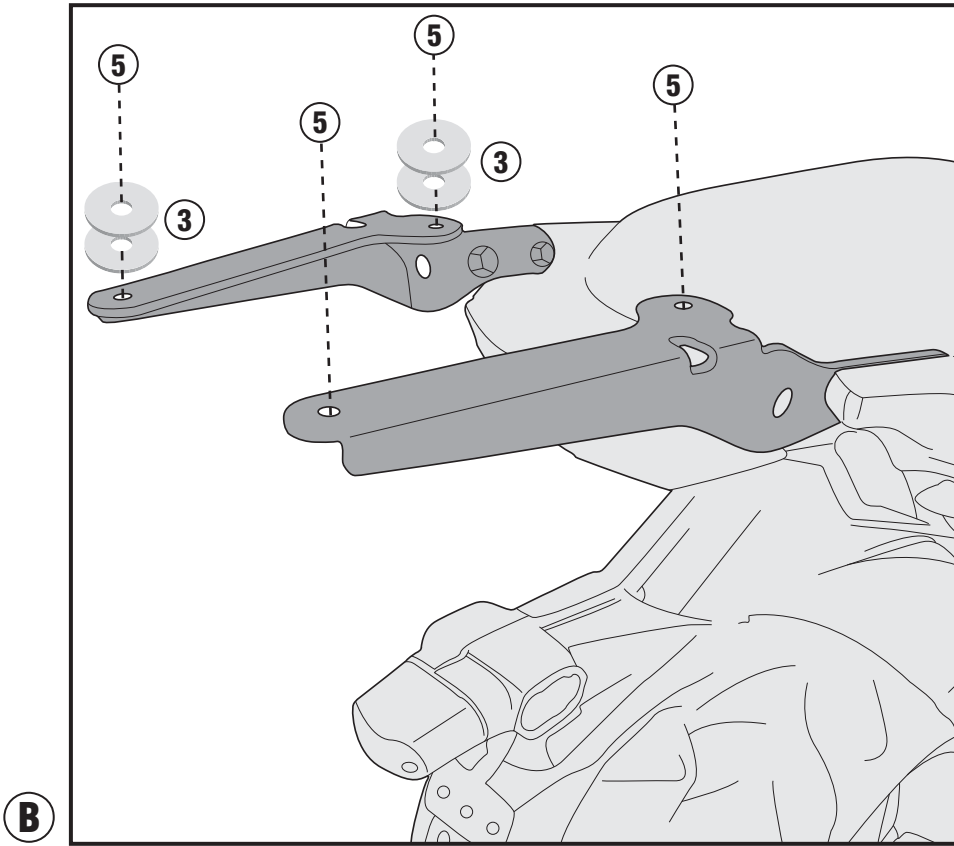

SR4114 - KR4114

PORTAPACCO SPECIFICO - SPECIFIC HOLDER - PORTE-PAQUET SPÉCIFIQUE - SPEZIFISCHER TRÄGER - PORTA-EQUIPAJE ESPECÍFICO - TRANSPORTADOR ESPECÍFICO

KAWASAKI VERSYS 650 (2015)

