



E9*22R06/02*6313*01

Ext.01

Página / Page 1/2

Comunicación sobre / *Concerning* ⁽¹⁾:

- ~~concesión de la homologación / approval granted~~
- ~~extensión de la homologación / approval extended~~
- ~~denegación de la homologación / approval refused~~
- ~~retirada de homologación / approval withdrawn~~
- ~~cese definitivo de la producción / production definitely discontinued~~

de un tipo de casco de protección con/sin ⁽¹⁾ un/varios ⁽¹⁾ tipo(s) de pantalla, con/sin ⁽¹⁾ un/varios ⁽¹⁾ tipo(s) de accesorio específico en aplicación del Reglamento UN N° 22 / *of a type of protective helmet with/without ⁽¹⁾ one/more ⁽¹⁾ visor type(s), with/without ⁽¹⁾ one/more ⁽¹⁾ specific accessory type(s) pursuant to UN Regulation No. 22.*

Homologación N° / *Approval No.*: E9*22R06/02*6313*01

Extensión N° / *Extension No.* 01

Motivos de la extensión / *Reasons for extension*: Inclusión de denominaciones comerciales y nueva visera. / *Inclusion of commercial denominations and new peak.*

1. Marca de fábrica o comercial / *Trade mark*: MHR, LS2, TAKAI, KTM
2. Tipo / *Type*: MX703
3. Tallas / *Sizes*: XS(53-54), S(55-56), M(57-58), L(59-60), XL(61-62), XXL(63-64), XXXL(65-66)
4. Nombre del fabricante / *Manufacturer's name*:
JIANGMEN PENGCHENG HELMETS LTD.
5. Dirección / *Address*:
No.01-7 Dongsheng Road, Gonghe Town, Heshan, Jiangmen City,
Guangdong, 529728 P.R. China
6. Nombre del representante, en su caso / *If applicable, name of manufacturer's representative*: ----
7. Dirección / *Address*: ----
8. Breve descripción del casco / *Brief description of helmet*:
Ver documentación del fabricante / *See manufacturer's documentation*
9. Casco sin mentón (J) / con mentón protectorio (P) / ~~con mentón no protectorio (NP) / con mentón protectorio móvil o extraíble (P/J)~~ ⁽¹⁾ / *Helmet without lower face cover (J) / with protective lower face cover (P) / with non-protective lower face cover (NP) / with detachable or movable protective lower face cover (P/J)* ⁽¹⁾
10. Tipo de pantalla o pantallas / *Type of visor or visors*: ----
11. Breve descripción de la pantalla o pantallas y pantalla interior si la hay / *Brief description of visor or visors and inner visor if any*: ----

(1) Táchese lo que no proceda / *Strike out what does not apply*





E9*22R06/02*6313*01

Ext.01

Página / Page 2/2

12. Casco preparado para accesorio específico (SA)/preparado para accesorios universales (UA)⁽¹⁾ /
Helmet ready for specific accessory (SA)/ready for universal accessories (UA)⁽¹⁾
13. Accesorios incluidos en la homologación del casco y funcionalidad / *Accessories included in the helmet homologation and functionality: ----*
14. Si casco UA, altavoces (S o S45) / Micrófono (M) / Montaje frontal (F) / Montaje lateral (L) / Montaje trasero (R)⁽¹⁾ / *If UA helmet, speakers (S or S45) / Microphone (M) / Front mounting (F) / Side mounting (L), Rear mounting (R)*⁽¹⁾
15. Presentado a la homologación el / *Submitted for approval on: 06.05.2022, 24.03.2023*
16. Servicio técnico encargado de los ensayos de homologación / *Technical service responsible for conducting approval tests: IDIADA*
17. Fecha del acta de los ensayos emitida por este servicio / *Date of report issued by that service: 30.06.2022, 24.03.2023*
18. N° del acta de ensayos emitida por este servicio / *Number of report issued by that service: MT21080001, MT23030155*
19. Observaciones / *Comments: ----*
20. Homologación ~~concedida~~ / extendida / ~~denegada~~ / retirada⁽¹⁾ /
Approval ~~granted~~ / extended / ~~refused~~ / ~~withdrawn~~⁽¹⁾
21. Lugar / *Place: Madrid*
22. Fecha / *Date: Ver firma electrónica / See electronic signature*
23. Firma / *Signature:*
EL SUBDIRECTOR GENERAL DE CALIDAD Y SEGURIDAD INDUSTRIAL
Resolución P.D. del DIRECTOR GENERAL DE INDUSTRIA Y DE LA PYME de 25-10-2012
24. Los siguientes documentos, que llevan el número de homologación arriba indicado, pueden ser obtenidos a solicitud del interesado / *The following documents, bearing the approval number shown above, are available on request:*
 - * Informe técnico / *Technical report*
 - * Documentación técnica del fabricante / *Manufacturer's technical documentation*

(1) Táchese lo que no proceda / *Strike out what does not apply*





Anexo - Información adicional sobre esta Homologación de tipo

Condiciones de la autorización y pie de recurso

Los vehículos, sistemas, componentes o unidades técnicas independientes fabricados en virtud de esta homologación de tipo deben estar identificados y portar las marcas correspondientes según la reglamentación aplicable.

La producción en serie de vehículos, sistemas, componentes y unidades técnicas independientes debe realizarse de acuerdo con la documentación de homologación. Todo cambio en la producción individualizada requerirá autorización expresa previa por parte de la Autoridad de Homologación Española.

Cualquier modificación en los datos incluidos en el certificado de homologación, como el nombre de la empresa, representante en la UE, dirección y las plantas de fabricación deben ser comunicados inmediatamente a la Autoridad de Homologación Española.

La homologación perderá su validez cuando la misma haya sido retirada o el tipo ya no cumpla con los requisitos legales. La retirada tendrá lugar siempre que hayan dejado de cumplirse los requisitos necesarios para la concesión y mantenimiento de la misma, cuando el fabricante no pueda demostrar a la Autoridad de Homologación el cumplimiento con los requisitos y procedimientos para garantizar la conformidad de la producción, en caso de que el titular no cumpla con sus obligaciones inherentes a la homologación o cuando se determine que el tipo homologado no cumple con los requisitos de seguridad y medio ambiente.

La Autoridad de Homologación de Tipo española podrá verificar el cumplimiento de las obligaciones del fabricante en cualquier momento. En particular, se podrá comprobar la correspondencia del producto con el tipo homologado, así como las medidas establecidas para garantizar la conformidad de la producción. A tal efecto se podrán tomar o solicitar las muestras necesarias. Se permitirá el acceso sin trabas a las instalaciones de producción y almacenamiento a los empleados o representantes de la Autoridad de Homologación Española.

La autorización objeto de esta resolución de homologación de tipo no es transferible. Los derechos de marca de terceros no se encuentran afectados por esta homologación.

Contra la presente Resolución, que no pone fin a la vía administrativa, podrá interponerse recurso de alzada ¹ ante la Dirección General de Industria y de la Pequeña y Mediana empresa, o ante la Secretaría General de Industria y de la Pequeña y Mediana empresa, en el plazo de un mes a partir del día siguiente a su notificación, de conformidad con los artículos 121 y 122 de la Ley 39/2015, de 1 de octubre, del Procedimiento Administrativo Común de las Administraciones Públicas.

¹ Nota: Para interponer recurso de alzada deberá acceder al siguiente enlace:
<https://sede.serviciosmin.gob.es/es-es/procedimientoselectronicos/Paginas/detalle-procedimientos.aspx?IdProcedimiento=157>





Annex - Additional Information on this Type Approval

Collateral clauses and right to appeal (Courtesy translation)

All vehicles, systems, components or separate technical units which correspond to the approved type are to be identified and marked according to the applied regulation.

The serial fabrication of vehicles, systems, components or separate technical must be in exact accordance with the approval documents. Changes in the individual production are only allowed with express consent of the Spanish Type Approval Authority.

Changes in the data included in the approval certificate, such as the name of the company, EU representative, address and the manufacturing plant are to be immediately disclosed to the Spanish Type Approval Authority.

The approval expires if it is withdrawn or if the type approved no longer complies with the legal requirements. The revocation can be made if the demanded requirements for issuance and the continuance of the approval no longer exist, if the manufacturer cannot demonstrate to the Type Approval Authority that it comply with the requirements and procedures to guarantee the conformity of production, if the holder of the approval violates the duties involved in the approval or if it is determined that the approved type does not comply with the requirements of traffic safety or environmental protection.

The Spanish Type Approval Authority may check the proper exercise of the conferred authority taken from this approval at any time. In particular, this means the compliant production as well as the measures for conformity of production. For this purpose, samples can be taken or have taken. The employees or the representatives of the Spanish Type Approval Authority may get unhindered access to the production and storage facilities.

The authorization contained with issuance of this approval is not transferable. Trade mark rights of third parties are not affected with this approval.

This approval does not conclude the administrative channel and can be appealed² within one month after notification, according to articles 121 and 122 of Ley 39/2015, de 1 de octubre, del Procedimiento Administrativo Común de las Administraciones Públicas. The appeal is to be addressed to Dirección General de Industria y de la Pequeña y Mediana empresa, or Secretaría General de Industria y de la Pequeña y Mediana empresa.

² Note: Appeal on the following link:

<https://sede.serviciosmin.gob.es/es-es/procedimientoselectronicos/Paginas/detalle-procedimientos.aspx?IdProcedimiento=157>





INFORME N° / REPORT No. MT23030155

CASCOS DE PROTECCIÓN, SUS PANTALLAS Y SUS ACCESORIOS PARA CONDUCTORES Y PASAJEROS DE MOTOCICLETAS Y CICLOMOTORES SEGÚN EL REGLAMENTO UN N° 22R06/02
PROTECTIVE HELMETS, THEIR VISORS AND THEIR ACCESSORIES FOR DRIVERS AND PASSENGERS OF MOTORCYCLES AND MOPEDS ACCORDING TO UN REGULATION No. 22R06/02

EXTENSION I

Fabricante / *Manufacturer* ⁽¹⁾ : JIANGMEN PENGCHENG HELMETS Ltd.
No.01-7 Dongsheng Road, Gonghe Town, Heshan, Jiangmen City,
Guangdong, 529728 P.R. China

Marca(s) / *Make(s)* ⁽¹⁾ : MHR, LS2, TAKAI, KTM

Tipo / *Type* ⁽¹⁾ : MX703

Denominaciones comerciales /
Commercial denominations ⁽¹⁾ : MX703-1, X-FORCE, MX703-2, MX703-6

Lugar y fecha de emisión del
informe / *Test report place and date* : L'Albornar, Santa Oliva (Tarragona)
24.03.2023

CONCLUSIONES / CONCLUSIONS: La modificación introducida en el casco, como se detalla en el anexo a este informe, es motivo de extensión de homologación respecto al casco tipo (exp. IDIADA N° MT21080001) y CUMPLE con las especificaciones relativas a la homologación de cascos, pantallas y accesorios de protección para conductores y pasajeros de motocicletas y ciclomotores, correspondientes al Reglamento UN N° 22R06/02. / *Modification introduced to the helmet, as detailed in the annex to this report, grant grounds for approval extension with respect to formerly certified helmet-type (IDIADA Report No. MT21080001) and FULFILLS the specifications relating to the homologation of helmets, their visors and their accessories of protection for riders and passengers of motorcycles and mopeds, according to UN Regulation No. 22R06/02.*

Realizado / *Performed by* :

Antonio Santos Carreño
TÉCNICO DE HOMOLOGACIONES
HOMOLOGATION TECHNICIAN

Vº. Bº. / *Revised by* :

Víctor Costa Escarrà
JEFE DE DEPARTAMENTO
DEPARTMENT MANAGER

* LOS RESULTADOS PRESENTADOS SE REFIEREN ÚNICAMENTE A LA MUESTRA ENSAYADA.
THE PRESENTED RESULTS REFER ONLY TO THE TESTED SAMPLE

* QUEDA TERMINANTEMENTE PROHIBIDA LA REPRODUCCION PARCIAL DE ESTE INFORME SIN PERMISO EXPRESO DE IDIADA.
THE PARTIAL REPRODUCTION OF THIS REPORT WITHOUT THE PERMISSION OF IDIADA IS COMPLETELY FORBIDDEN



ANEXO AL INFORME / ANNEX TO THE TEST REPORT

MOTIVOS DE EXTENSIÓN / EXTENSION REASONS

- Inclusión de las denominaciones comerciales / *Inclusion of the commercial denominations*: MX703-2, MX703-6
- Inclusión de nueva visera / *Inclusion of a new peak*

IDENTIFICACIÓN DEL PROYECTO / PROJECT IDENTIFICATION

Fabricante / *Manufacturer* ⁽¹⁾ : JIANGMEN PENGCHENG HELMETS Ltd.
 No.01-7 Dongsheng Road, Gonghe Town, Heshan, Jiangmen City,
 Guangdong, 529728 P.R. China

Marca(s) / *Make(s)* ⁽¹⁾ : MHR, LS2, TAKAI, KTM

Tipo / *Type* ⁽¹⁾ : MX703

Denominaciones comerciales / *Commercial denominations* ⁽¹⁾ : MX703-1, X-FORCE, MX703-2, MX703-6

Lugar / *Place* : L'Albornar, Santa Oliva (Tarragona)
 Fecha / *Date* : 24.03.2023

Antonio Santos Carreño
 TÉCNICO DE HOMOLOGACIONES
 HOMOLOGATION TECHNICIAN

⁽¹⁾ Información proporcionada por el cliente. El laboratorio no se hace responsable de dicha información / *Information provided by the client. The laboratory is not responsible for such information*

- * LOS RESULTADOS PRESENTADOS SE REFIEREN ÚNICAMENTE A LA MUESTRA ENSAYADA.
THE PRESENTED RESULTS REFER ONLY TO THE TESTED SAMPLE.
- * QUEDA TERMINANTEMENTE PROHIBIDA LA REPRODUCCIÓN PARCIAL DE ESTE INFORME SIN PERMISO EXPRESO DE IDIADA.
THE PARTIAL REPRODUCTION OF THIS REPORT WITHOUT THE PERMISSION OF IDIADA IS COMPLETELY FORBIDDEN.
- * EL LABORATORIO HA CALCULADO LA INCERTIDUMBRE DE MEDIDA ASOCIADA A LOS RESULTADOS.
MEASUREMENT UNCERTAINTY OF THE RESULTS HAS BEEN CALCULATED BY THE LABORATORY.
- * LA REGLA DE DECISIÓN UTILIZADA, SEGÚN LA NORMA ILAC-G8, HA SIDO LA DECLARACIÓN BINARIA DE ACEPTACIÓN SIMPLE.
THE DECISION RULE USED, ACCORDING TO THE ILAC-G8 STANDARD, WAS THE BINARY STATEMENT FOR SIMPLE ACCEPTANCE.

DOCUMENTACIÓN TÉCNICA /
TECHNICAL DOCUMENTATION



**R22.06/ECE TYPE-APPROVAL OF PROTECTIVE HELMETS AND THEIR VISORS FOR DRIVERS
AND PASSENGERS OF MOTORCYCLES AND MOPEDS**

INDEX OF DOCUMENTATION

Page	Concept	Date
1	GENERAL INFORMATION	MAR. 2023
2	DESCRIPTION OF THE HELMET / SHELL / RETENTION SYSTEM	JUN. 2022
3	PROTECTIVE PADDING / ACCESSORIES	MAR. 2023
4	ASSEMBLY DRAWING (I)	JUN. 2022
5	ASSEMBLY DRAWING (II)	MAR. 2023
6	DRAWING OF THE HELMET WITH DIMENSIONS (Shell 1 and 2)	JUN. 2022
7	DRAWING OF THE HELMET WITH DIMENSIONS (Shell 3 and 4)	JUN. 2022
8	DRAWING OF PROTECTIVE PADDING (Sizes XXXL-XL)	JUN. 2022
9	DRAWING OF PROTECTIVE PADDING (Size L)	JUN. 2022
10	DRAWING OF PROTECTIVE PADDING (Size M)	JUN. 2022
11	DRAWING OF PROTECTIVE PADDING (Size S)	JUN. 2022
12	DRAWING OF PROTECTIVE PADDING (Size XS)	JUN. 2022
13	DRAWING OF THE MIDDLE PROTECTIVE PADDING (All sizes)	JUN. 2022
14	DRAWING OF THE RETENTION SYSTEM	JUN. 2022
15	DRAWING OF THE PEAK (VERSION 1)	JUN. 2022
16	DRAWING OF THE PEAK (VERSION 2)	MAR. 2023
17	MARKING	JUN. 2022
18	USER INSTRUCTIONS (I)	JUN. 2022
19	USER INSTRUCTIONS (II)	JUN. 2022
20	USER INSTRUCTIONS (III)	JUN. 2022
21	USER INSTRUCTIONS (IV)	JUN. 2022

Extension reasons:

- **Inclusion of the commercial denominations: MX703-2, MX703-6**
- **Inclusion of a new peak**

TYPE:
MX703



DATE : MAR. 2023
EXT. : 01
PAGE : 1/21

**R22.06/ECE TYPE-APPROVAL OF PROTECTIVE HELMETS AND THEIR VISORS FOR DRIVERS
AND PASSENGERS OF MOTORCYCLES AND MOPEDS**

1. GENERAL INFORMATION

1.1 Trade mark(s):

MHR, LS2, TAKAI, KTM

1.2 Type:

MX703

1.3 Variants:

1.4. Commercial denominations:

MX703-1, X-FORCE, MX703-2, MX703-6

1.5. Name and address of manufacturer:

**JIANGMEN PENGCHENG HELMETS LTD.
No.01-7 Dongsheng Road, Gonghe Town, Heshan,
Jiangmen City, Guangdong, 529728 P.R. China**

1.6. Name and address of assembly plant:

**JIANGMEN PENGCHENG HELMETS LTD.
No.01-7 Dongsheng Road, Gonghe Town, Heshan,
Jiangmen City, Guangdong, 529728 P.R. China**



**R22.06/ECE TYPE-APPROVAL OF PROTECTIVE HELMETS AND THEIR VISORS FOR DRIVERS
AND PASSENGERS OF MOTORCYCLES AND MOPEDS**

2. DESCRIPTION OF THE HELMET

2.1. Type of helmet: **FULL FACE**

2.2. Protective option:

Helmet with protective lower face cover (P)

2.3. Shell size(s) and size range in cms:

Shell 1: XL(61-62cm), XXL(63-64cm), XXXL(65-66cm)

Shell 2: L(59-60cm)

Shell 3: M(57-58cm)

Shell 4: XS(53-54cm), S(55-56cm)

3. SHELL

3.1. Material used: **Carbon fiber**

3.2. Ventilations:

3.2.1. Number of ventilations: **15**

4. RETENTION SYSTEM

4.1. Chin strap:

4.1.1. Material: **Nylon**

4.1.2. Width: **22 ± 1 mm**

4.2. Type of buckle(s):

Double-D rings



**R22.06/ECE TYPE-APPROVAL OF PROTECTIVE HELMETS AND THEIR VISORS FOR DRIVERS
AND PASSENGERS OF MOTORCYCLES AND MOPEDS**

5. PROTECTIVE PADDING

5.1. Composition: **Expanded polystyrene**

5.2. Density:

Size	Main Part Kg/m ³	Side Part Kg/m ³	Chin Part Kg/m ³
XS	24	40	80
S	24	40	
M	24	40	
L	35	50	
XL	35	55	
XXL			
XXXL			

5.3. Weight:

Size	Main Part grs	Side Part grs	Chin Part grs
XS	80 ± 5g	50 ± 2g	4 ± 1g
S	77 ± 5g	45 ± 2g	
M	77 ± 5g	48 ± 2g	
L	122 ± 5g	60 ± 2g	
XL	140 ± 5g	70 ± 2g	
XXL			
XXXL			

6. ACCESSORIES

6.1. **Peak:**
Included as an optional accessory.
Version 1: See pages 4 and 15.
Version 2: See pages 5 and 16.

TYPE:
MX703



DATE : MAR. 2023
EXT. : 01
PAGE : 4/21

R22.06/ECE TYPE-APPROVAL OF PROTECTIVE HELMETS AND THEIR VISORS FOR DRIVERS
AND PASSENGERS OF MOTORCYCLES AND MOPEDS

ASSEMBLY DRAWING (I)
(With Peak version 1)

12	后风窗 back vent	个 piece	4	Alloy Material
11	顶风窗 TOP vent	个 piece	4	Alloy Material
10	侧檐 peak	个 piece	1	Alloy Material
9	前风窗 Front vent	个 piece	1	Alloy Material
8	视野胶条 visor	个 piece	1	PP
7	下巴风窗 mouth vent	套 set	1	Alloy Material
6	颌带 chin strap	条 unit	2	nylon
5	快拆扣/固定环扣 lock/locking ring	套 set	1	stainless steel
4	下巴边 rubber ring	条 unit	1	pvc
3	内衬 comfort padding	套 set	1	nylon
2	泡沫 protective padding	个 piece	5	eps
1	壳体 Outer shell	个 piece	1	carbon fibre
序号 number	名称 name	单位 unit	数量 piece	材料 material

MODEL	MX703-XXXL-XS								
SIZE	XXXL	XXL	XL	L	M	S	XS		
cm	66-65	64-63	62-61	60-59	58-57	56-55	54-53		

技术要求
technical requirement

1. The surface of the outshell should be smooth and bright no mottle, pinhold, bulb, drop lack of oil, discolorie of basic color.
2. Every spare parts should be fixed correctly , and not be loose, missed.

MT23030155

IDIADA

TYPE:
MX703



DATE : MAR. 2023
EXT. : 01
PAGE : 5/21

R22.06/ECE TYPE-APPROVAL OF PROTECTIVE HELMETS AND THEIR VISORS FOR DRIVERS
AND PASSENGERS OF MOTORCYCLES AND MOPEDS

ASSEMBLY DRAWING (II)
(With Peak version 2)

12	后风窗 back vent	个 piece	4	Alloy Material
11	顶风窗 TOP vent	个 piece	4	Alloy Material
10	帽檐 peak	个 piece	1	nylon
9	前风窗 Front vent	个 piece	1	Alloy Material
8	视野胶条 visor	个 piece	1	PP
7	下巴风窗 mouth vent	套 set	1	Alloy Material
6	帽带 chin strap	条 unit	2	nylon
5	快拆扣/磁吸扣/插扣 buckle/buckle/ring	套 set	1	stainless steel
4	下胶圈 rubber ring	条 unit	1	pvc
3	内衬 comfort padding	套 set	1	nylon
2	泡沫 protective padding	个 piece	5	eps
1	壳体 Outer shell	个 piece	1	carbon fiber
序号 number	名称 name	单位 unit	数量 piece	材料 material

MODEL								
MX703-XXXL-XS								
SIZE	XXXL	XXL	XL	L	M	S	XS	
CM	66-65	64-63	62-61	60-59	58-57	56-55	54-53	

技术要求
Technical requirement

1. The surface of the outshell should be smooth and bright no mottle, pinhold, bulb, drop lack of oil, discolour of basic color.
2. Every spare parts should be fixed correctly, and not be loose, missed.

TYPE:
MX703



DATE : MAR. 2023
EXT. : 01
PAGE : 6/21

R22.06/ECE TYPE-APPROVAL OF PROTECTIVE HELMETS AND THEIR VISORS FOR DRIVERS
AND PASSENGERS OF MOTORCYCLES AND MOPEDS

DRAWING OF THE HELMET WITH DIMENSIONS (Shell 1 and 2)

MX703-XXXL-XL-KT

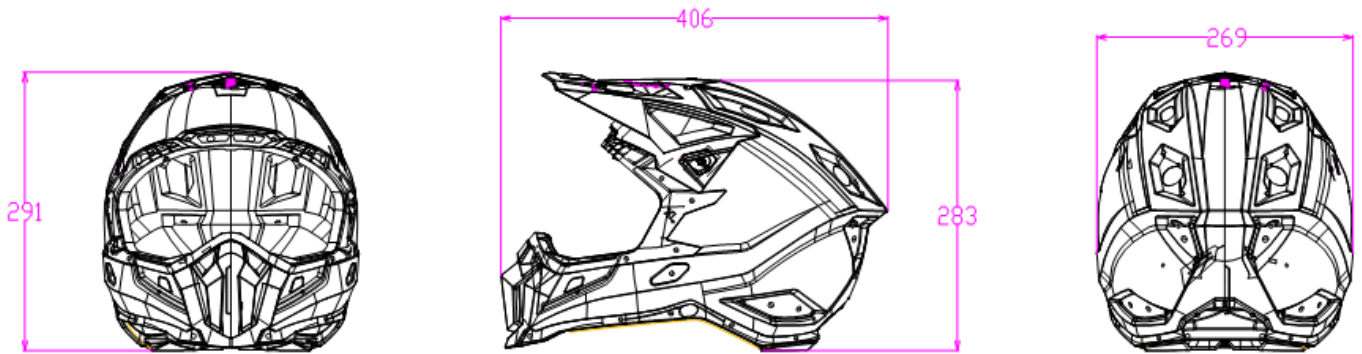

MX703-L-KT

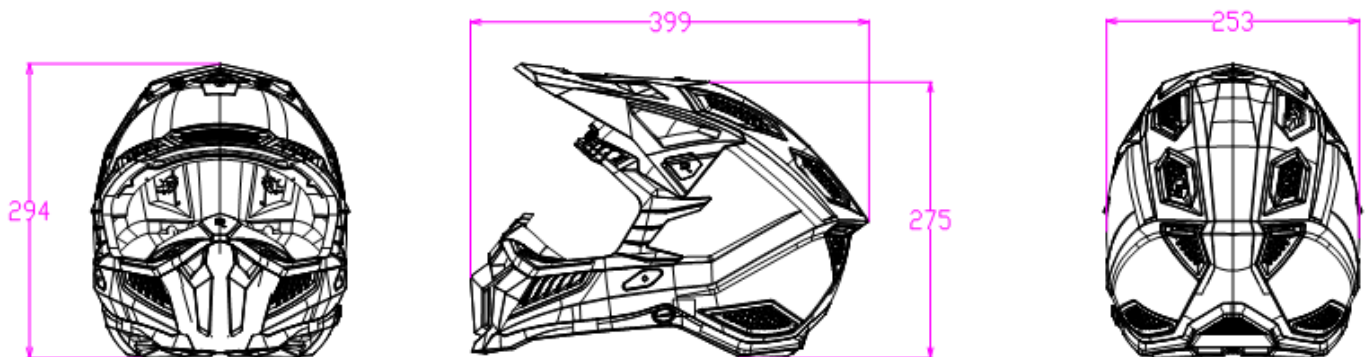

MT23030155

İBİADÄ

TYPE:
MX703



DATE : MAR. 2023
EXT. : 01
PAGE : 7/21

R22.06/ECE TYPE-APPROVAL OF PROTECTIVE HELMETS AND THEIR VISORS FOR DRIVERS
AND PASSENGERS OF MOTORCYCLES AND MOPEDS

DRAWING OF THE HELMET WITH DIMENSIONS (Shell 3 and 4)

MX703-M-KT

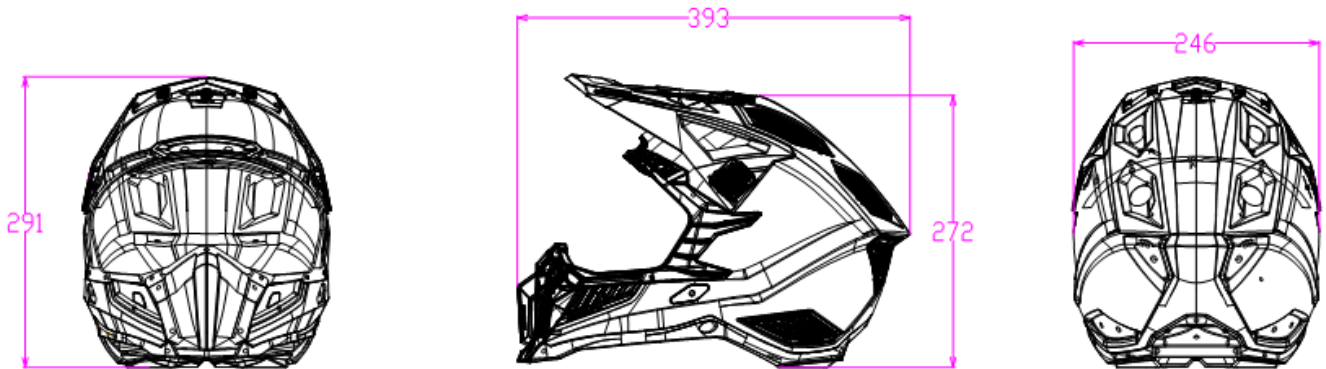

MX703-XS-S-KT

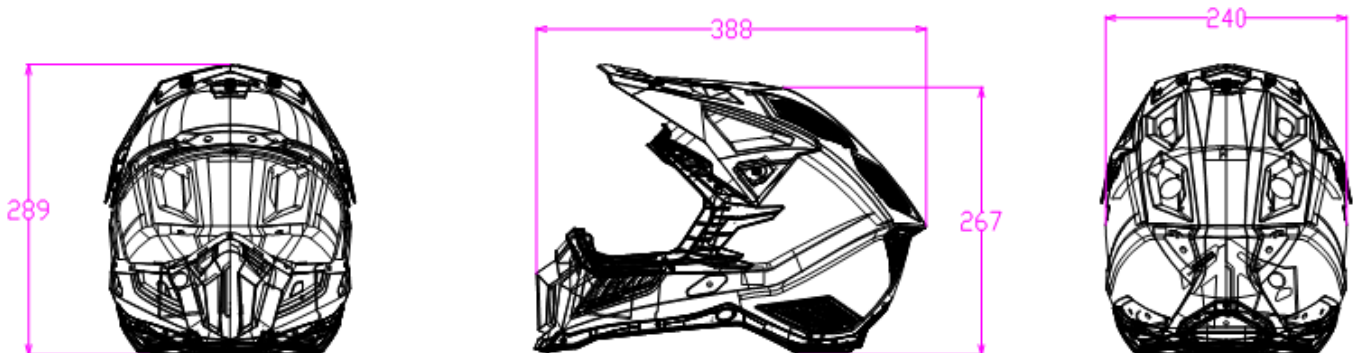

TYPE:
MX703



DATE : MAR. 2023
EXT. : 01
PAGE : 8/21

R22.06/ECE TYPE-APPROVAL OF PROTECTIVE HELMETS AND THEIR VISORS FOR DRIVERS
AND PASSENGERS OF MOTORCYCLES AND MOPEDS

DRAWING OF PROTECTIVE PADDING (Sizes XXXL-XL)

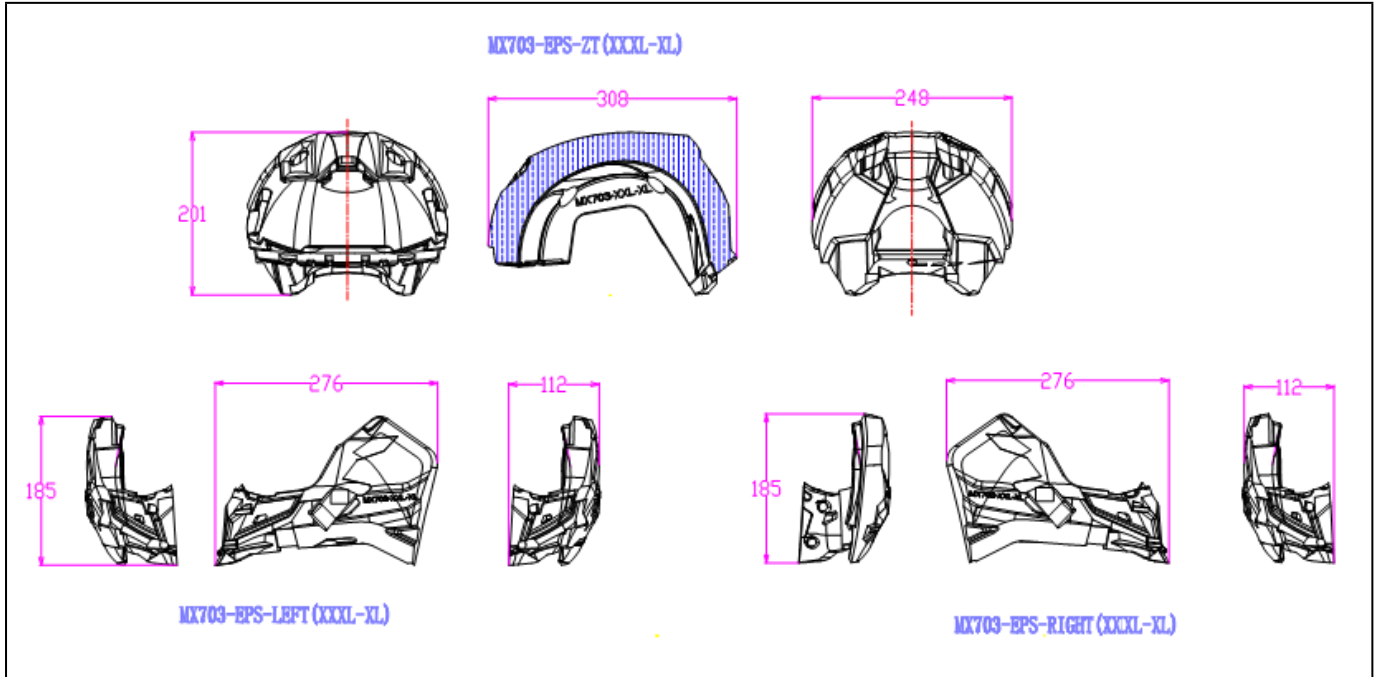

TYPE:
MX703



DATE : MAR. 2023
EXT. : 01
PAGE : 9/21

R22.06/ECE TYPE-APPROVAL OF PROTECTIVE HELMETS AND THEIR VISORS FOR DRIVERS
AND PASSENGERS OF MOTORCYCLES AND MOPEDS

DRAWING OF PROTECTIVE PADDING (Size L)

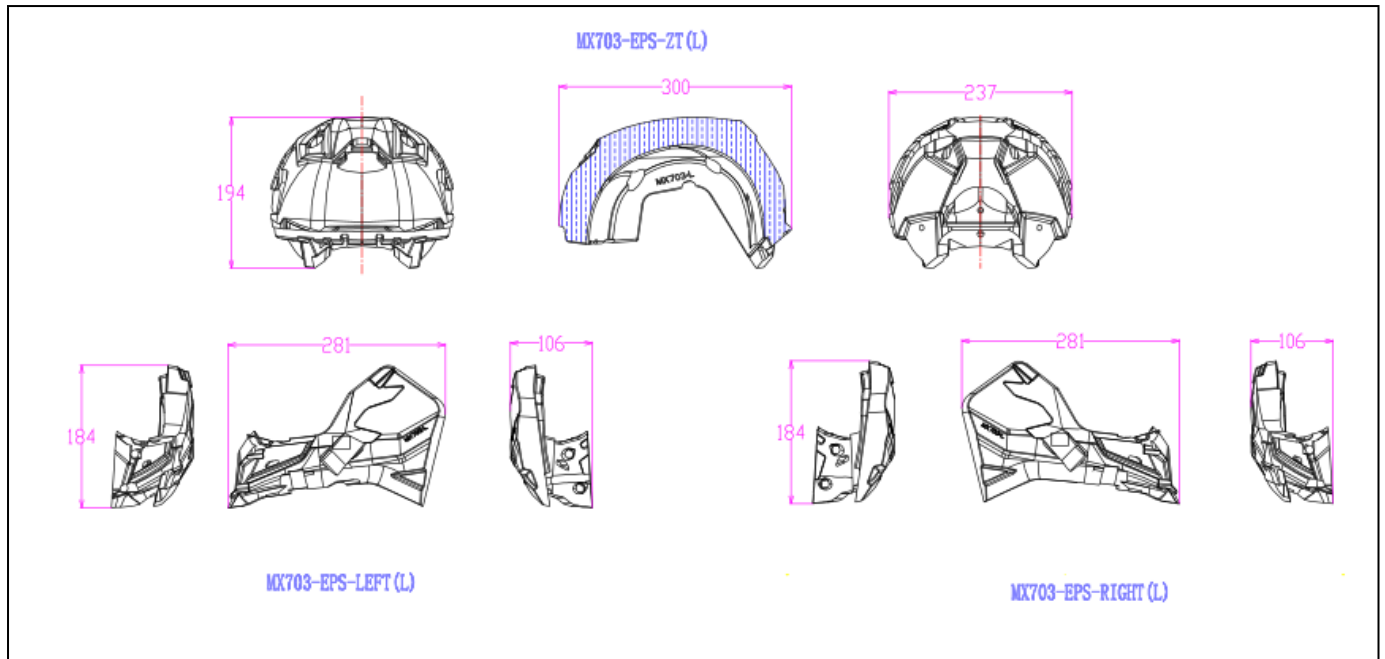

TYPE:
MX703



DATE : MAR. 2023
EXT. : 01
PAGE : 10/21

R22.06/ECE TYPE-APPROVAL OF PROTECTIVE HELMETS AND THEIR VISORS FOR DRIVERS
AND PASSENGERS OF MOTORCYCLES AND MOPEDS

DRAWING OF PROTECTIVE PADDING (Size M)

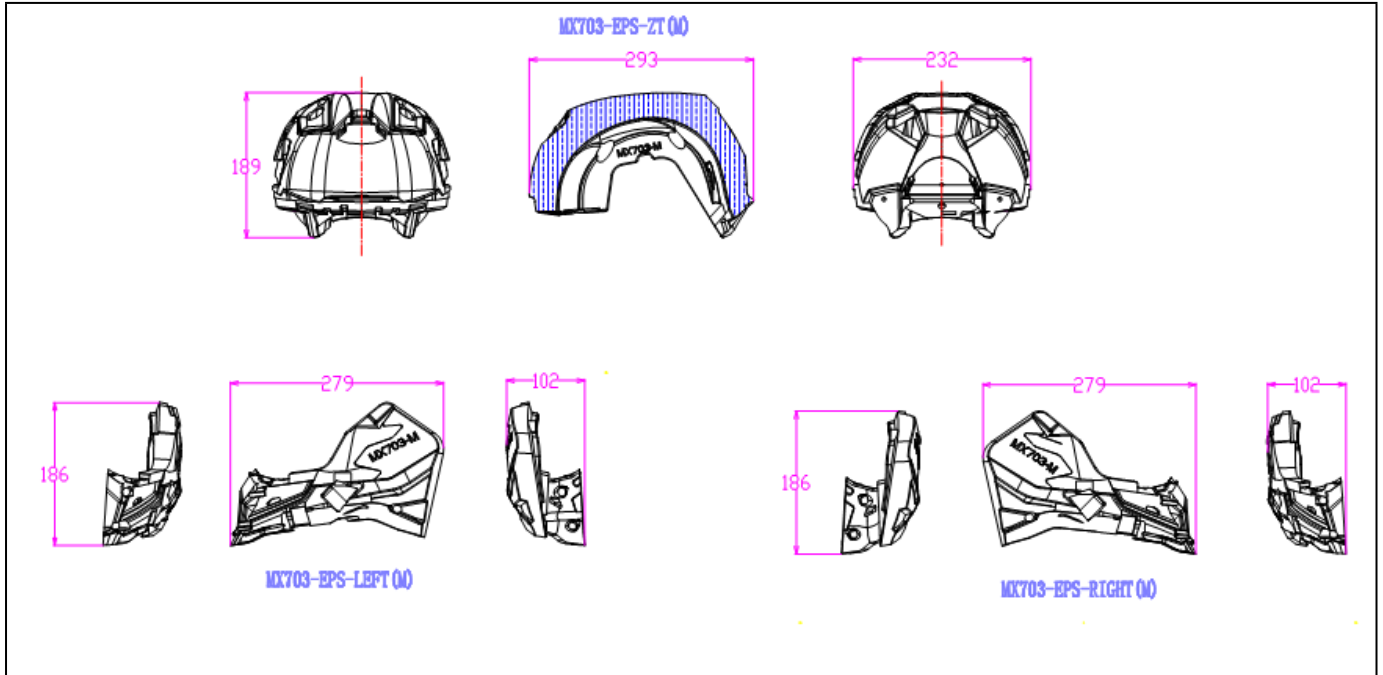

TYPE:
MX703



DATE : MAR. 2023
EXT. : 01
PAGE : 11/21

R22.06/ECE TYPE-APPROVAL OF PROTECTIVE HELMETS AND THEIR VISORS FOR DRIVERS
AND PASSENGERS OF MOTORCYCLES AND MOPEDS

DRAWING OF PROTECTIVE PADDING (Size S)

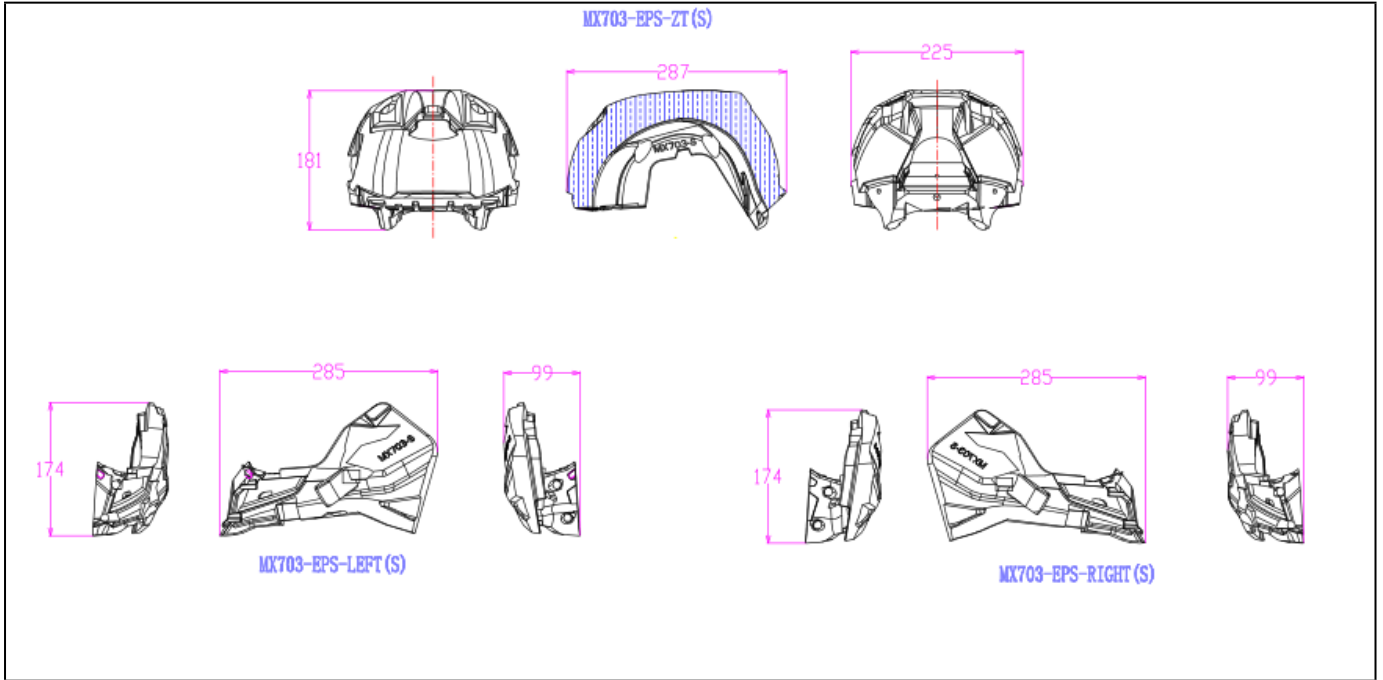

TYPE:
MX703



DATE : MAR. 2023
EXT. : 01
PAGE : 12/21

R22.06/ECE TYPE-APPROVAL OF PROTECTIVE HELMETS AND THEIR VISORS FOR DRIVERS
AND PASSENGERS OF MOTORCYCLES AND MOPEDS

DRAWING OF PROTECTIVE PADDING (Size XS)

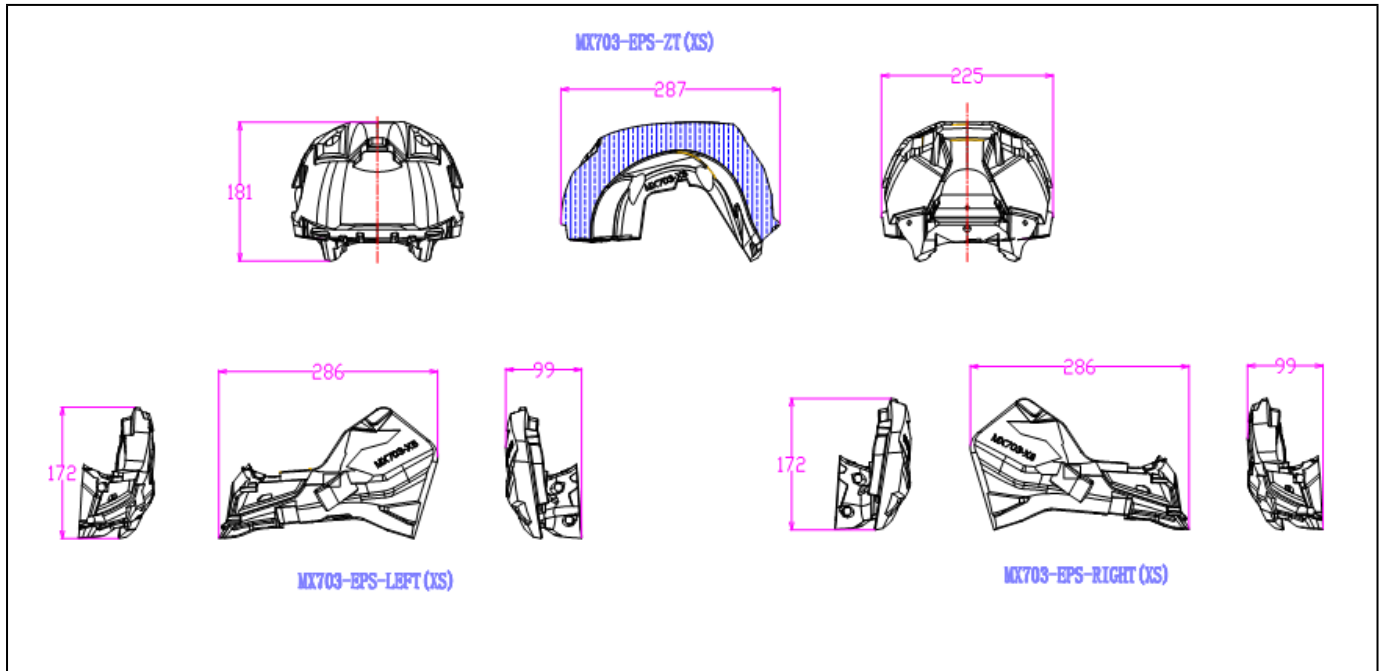

TYPE:
MX703



DATE : MAR. 2023
EXT. : 01
PAGE : 13/21

R22.06/ECE TYPE-APPROVAL OF PROTECTIVE HELMETS AND THEIR VISORS FOR DRIVERS
AND PASSENGERS OF MOTORCYCLES AND MOPEDS

DRAWING OF THE MIDDLE PROTECTIVE PADDING (All sizes)

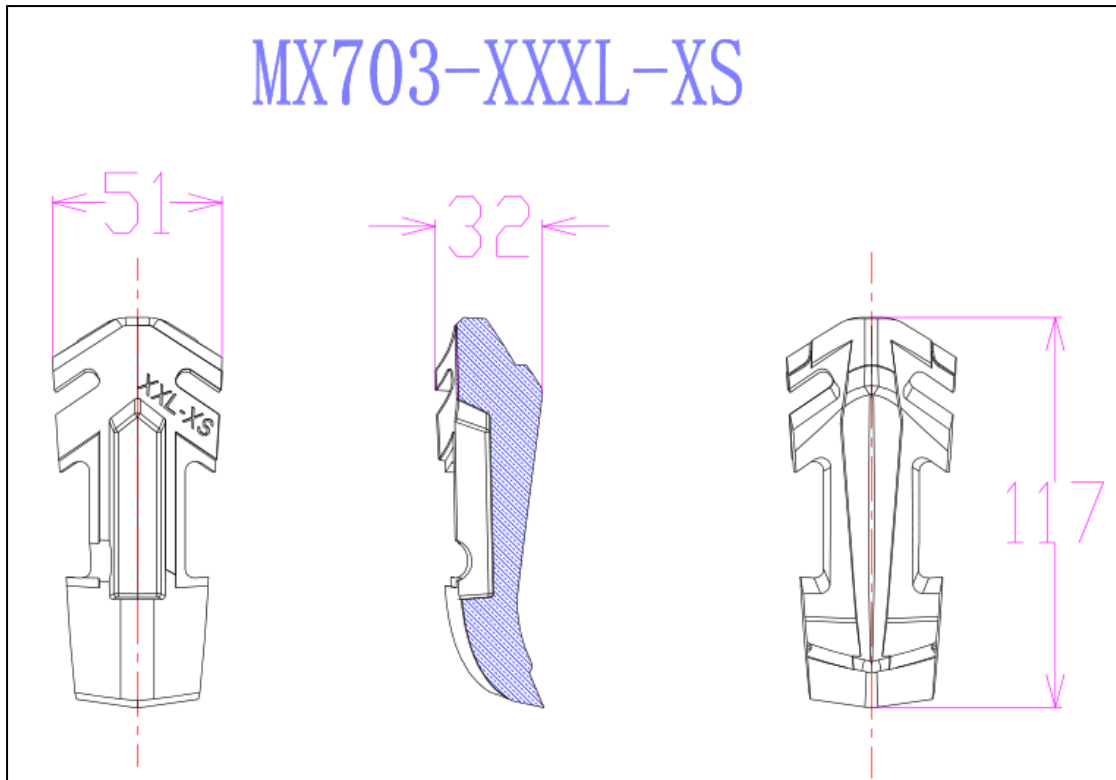

TYPE:
MX703



DATE : MAR. 2023
EXT. : 01
PAGE : 14/21

**R22.06/ECE TYPE-APPROVAL OF PROTECTIVE HELMETS AND THEIR VISORS FOR DRIVERS
AND PASSENGERS OF MOTORCYCLES AND MOPEDS**

DRAWING OF THE RETENTION SYSTEM

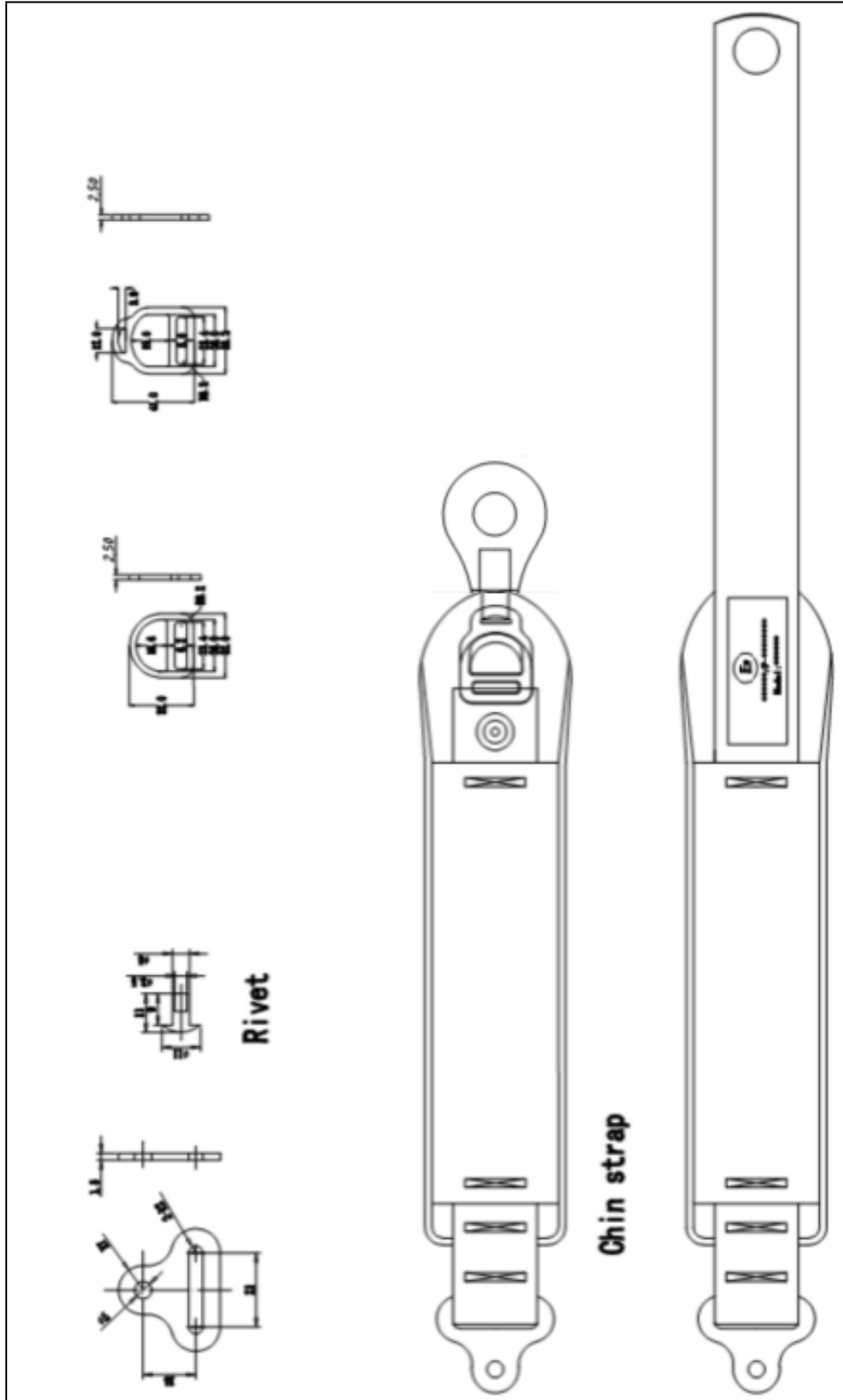

TYPE:
MX703



DATE : MAR. 2023
EXT. : 01
PAGE : 15/21

R22.06/ECE TYPE-APPROVAL OF PROTECTIVE HELMETS AND THEIR VISORS FOR DRIVERS
AND PASSENGERS OF MOTORCYCLES AND MOPEDS

DRAWING OF THE PEAK (Version 1)

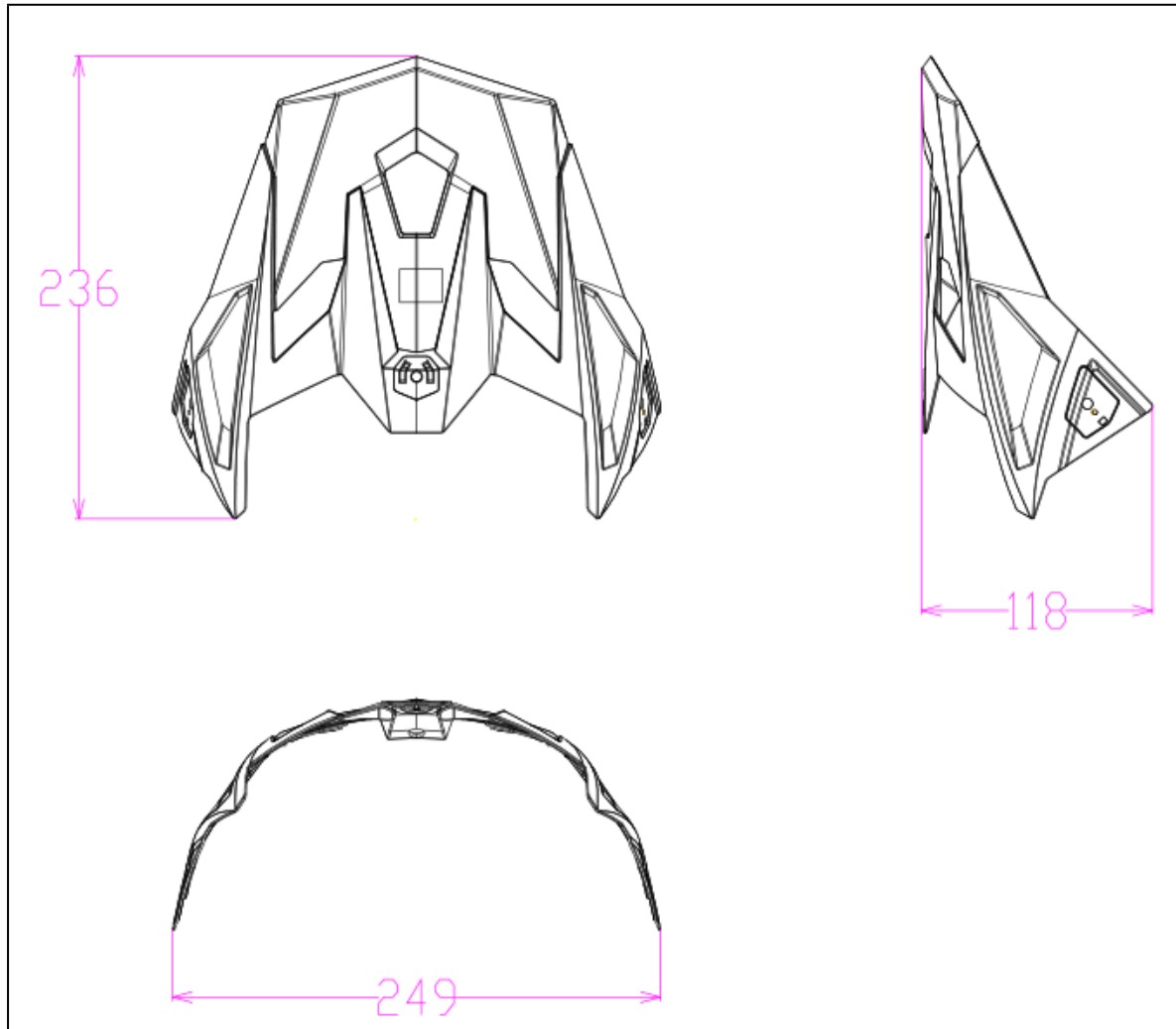

TYPE:
MX703



DATE : MAR. 2023
EXT. : 01
PAGE : 16/21

R22.06/ECE TYPE-APPROVAL OF PROTECTIVE HELMETS AND THEIR VISORS FOR DRIVERS
AND PASSENGERS OF MOTORCYCLES AND MOPEDS

DRAWING OF THE PEAK (Version 2)

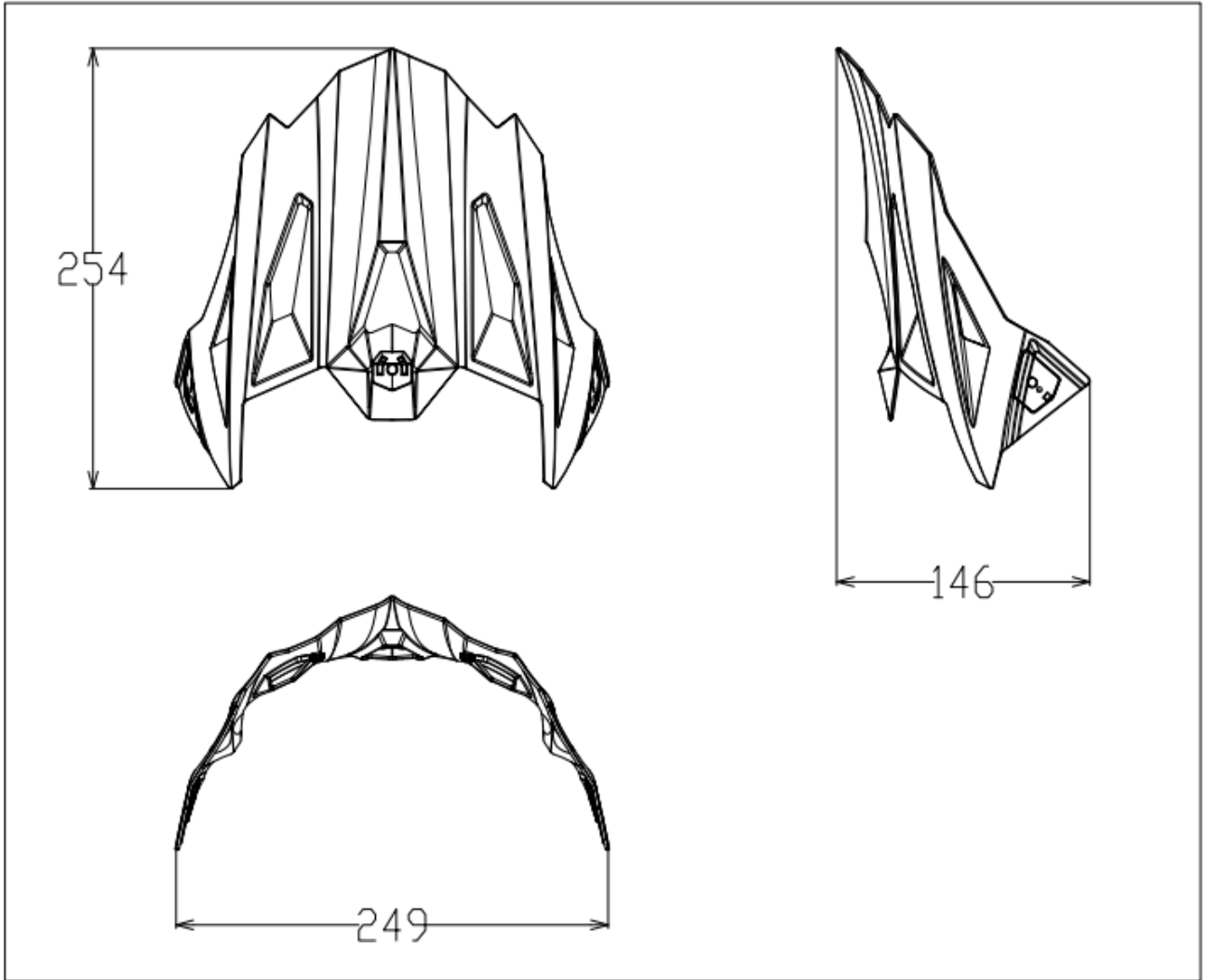

MT23030155

İİDİADÄ

TYPE:
MX703



DATE : MAR. 2023
EXT. : 01
PAGE : 17/21

R22.06/ECE TYPE-APPROVAL OF PROTECTIVE HELMETS AND THEIR VISORS FOR DRIVERS
AND PASSENGERS OF MOTORCYCLES AND MOPEDS

MARKING

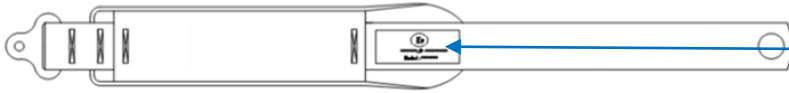

Approval Mark and Serial number



WARNING

ALWAYS CHECK YOUR HELMET BEFORE RIDING OFF.

①1. Check the shield and visor screws, and retighten them if necessary.

2. Check for cracks in the helmet. Strong acid (for example, battery acid) can damage the shield base. If you find crack damages, stop using the helmet immediately.

3. Plastic components may start to wear out about 5 years after manufacture. If you find deterioration in any part of a component, either replace the component or get a new helmet. If these parts come loose and/or fall off while you are riding, your vision may be blocked which could cause an accident.

4. Check the security of the retention system.

5. For adequate protection, this helmet must fit closely and be securely attached.

6. Any helmet that has sustained a violent impact should be replaced.

7. 'Warning' - Do not apply paint, stickers, petrol or other solvents to this helmet'.

CLEAN CAREFULLY YOUR HELMET

②1. Never use hot or salt water, benzene, gasoline, glass cleaner or other solvents. Your helmet could be seriously damaged by these substances without showing any apparent visible damage. A helmet damaged or weakened by a cleaning Agent may not provide head protection in an accident resulting serious personal injury or death. The correct way to clean a helmet is to mix 5 or 6 drops of mild soap in quart of warm water. Dampen a soft cloth with this solution and wipe the helmet clean. Rinse with a wet cloth.

Manufactured date:
Visor approved for this helmet:
DO NOT REMOVE THIS LABEL
Manufactured by MHR. Made in China



L (59-60) / 1150 g

TYPE:
MX703



DATE : MAR. 2023
EXT. : 01
PAGE : 18/21

R22.06/ECE TYPE-APPROVAL OF PROTECTIVE HELMETS AND THEIR VISORS FOR DRIVERS
AND PASSENGERS OF MOTORCYCLES AND MOPEDS

USER INSTRUCTIONS (I)



ALWAYS AHEAD



Download the manual



FR Pour assurer une protection suffisante, ce casque doit être bien ajusté et être solidement attaché. Tout casque qui a été soumis à un choc violent est à remplacer. Un casque OPEN FACE ne protège pas le menton en cas de choc.
Attention! N'appliquez sur ce casque ni peinture, ni autocollant, ni essence, ni aucun autre solvant.

ES Para asegurar una protección correcta, el casco debe estar bien ajustado y abrochado. Todo casco sometido a un choque violento tiene que ser reemplazado. Un casco OPEN FACE no protege la mandíbula en caso de choque.
¡Cuidado! No aplicar pintura, adhesivos, gasolina u otros disolventes sobre la superficie del casco.

IT Per garantire una buona protezione, il casco deve essere correttamente calzato ed allacciato. Ogni casco sottoposto ad un colpo violento, deve essere sostituito. Un casco OPEN FACE non protegge la mandibola in caso d'urto.
Attenzione! Non applicare pittura, adesivi, benzina od altri solventi sulla superficie del casco.

EN To assure complete protection this helmet must be a good fit and to be securely fastened. All helmets must be replaced if they are subject to impact damage. OPEN FACE helmets don't protect the chin in case of impact.
Attention! Do not use any paint, glue, petrol or any other thinner on this helmet.

DE Um ausreichenden Schutz gewährleisten zu können, muss dieser Helm gut passen und soll sicher befestigt werden. Alle Helme müssen, bei Beschädigungen, ersetzt werden. Ein Helm OPEN FACE dass Kinnstück ist nicht für Impact entwickelt.
Achtung! Verwenden Sie bitte Keine Farben, Aufkleber, Benzin oder andere Laugen, auf diesen Helm.



**R22.06/ECE TYPE-APPROVAL OF PROTECTIVE HELMETS AND THEIR VISORS FOR DRIVERS
AND PASSENGERS OF MOTORCYCLES AND MOPEDS**

USER INSTRUCTIONS (II)

Congratulations on purchasing your new **LS2** helmet. Please read these instructions carefully before use. They contain valuable information to help you obtain the most protection from your helmet and to ensure a longer life for your helmet. All our products come from the most advanced research in terms of active security and design. The very high level for aerodynamics and comfort will get you the best performances all along the road. Whatever can be your choice leisure, tourism, racing, one of the helmets from the LS2 range is the best solution for your active protection.

1. Read these instructions thoroughly before using your helmet for the first time and store them safely for future reference.
2. A helmet like all products may wear out over time depending upon its use and the amount of care that is given. Please check your helmet every time before use for damage and do not use a damaged helmet. The most known standards of homologation recommend a helmet life of five years. LS2 agrees with their recommendation even though your helmet does not show any signs of malfunction, visible damage or defect. We strongly recommend you replace your helmet five years after the original date of purchase. See also "ONE IMPACT RULE" of item 3 in this manual, which says clearly "helmet is designed to help absorb one impact".
3. If you have any questions or comments concerning this helmet, please contact your nearest LS2 dealer or agent. Note that these specifications are subject to change without notice, as we continually strive to improve our products.

HOW TO CHOOSE A HELMET AND WEAR IT CORRECTLY

No helmet can protect the wearer against all foreseeable high speed and low speed impact. However, for maximum head protection the helmet must be of proper fit and the retention system must be securely fastened under the chin. Failure to have proper fit and to securely fasten the helmet is dangerous as the helmet could come off in an accident resulting in severe head injury or death.

1 To determinate proper fit.

- 1.1. Measure your head size. Wrap a tape measure horizontally around your head at the height of about 2,5 cm above your eyebrows. This will establish the longest measurement around your head.
- 1.2. Select the helmet that is the closest match to your head size. If your head size should fit between two helmet sizes, try on the smaller one first.

2 Try the helmet on

- 2.1. Expand the helmet opening by the straps, and slide your head into the helmet. Pull the chin straps only, not the chin straps cover, pulling on the covers may rip them. If the helmet is not tight, it is too big for you. If you are unfamiliar with helmets you may be reluctant to pull down the helmet which should feel tight. Even if you feel it is difficult to put it on, please use the smallest helmet possible.



page 2

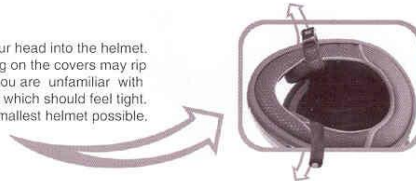

3 Check for a proper fit. With the helmet, go through the following checklist to determine whether the helmet is the correct size.

- 3.1. Make sure the inner lining fits snugly all around your head.
- 3.2. Make sure the top pad presses closely to the top of your head.
- 3.3. Check whether the cheek pads are in contact with your cheeks.
- 3.4. Make sure there is no space between inner lining and brow where you could insert your finger.
- 3.5. Now, take hold of the helmet with a hand on each side. Without moving your head, try to move the helmet up and down, and side to side. You should feel the skin of your head and face being pulled as you try to move the helmet. If you can move the helmet around easily, it is too big. Try a smaller size.



4 Check the retention system and go through the following steps.

- 4.1. Fasten the chinstrap as tight as possible without causing you pain (see diagram 2). There must be no slack in the strap and it must be tight up against your chin.
- 4.2. With the chinstrap secured, put your hands flat on the back of the helmet and try to push the helmet off by rotating forward.
- 4.3. Next, put your hands on the front of the helmet above your forehead (or on the chinguard) and try to push the helmet off by rotating it toward the rear.
- 4.4. If the helmet starts to come off in either direction, do not use the helmet, either the helmet is too large for you or the chin strap is not tightened enough.

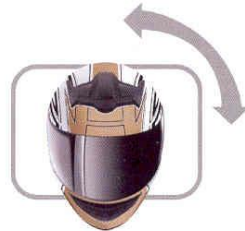

Tightening the chinstrap correctly is extremely important. Try to pull down on the chinstrap with the tips of your fingers if the strap is not against your chin or loosens, you have not properly put the strap through the D rings. Start again (see diagram 2) if your chinstrap is loose, the shock of an impact may knock your helmet off, leaving your head completely unprotected. Do not use a helmet that can be rolled off the head with the chinstrap fastened, since it may come off in an accident, resulting in death or serious personal injuries.

page 3



ENGLISH



**R22.06/ECE TYPE-APPROVAL OF PROTECTIVE HELMETS AND THEIR VISORS FOR DRIVERS
AND PASSENGERS OF MOTORCYCLES AND MOPEDS**

USER INSTRUCTIONS (III)

D RING: To securely fasten the D ring retention system, thread the end of the chinstrap through the D rings only as shown in diagram 2 and put it tight against your throat. Clip the chin strap end hook on the D ring as shown in diagram 2 to secure the loose end of the chin strap after it's securely fastening the chin strap. The only function of the chinstrap end hook fitted on the end of the chinstrap is to avoid fluttering of the end part of the chinstrap.

Quick-release retention system: To fasten the strap, push the metal tongue firmly into the buckle until it locks with a click. Pull the strap tight and pass the end of the strap through the strap ring or ladder to secure it. To release the strap, press the two catches inward (or slide the catches down).

SAFETY RECOMMENDATIONS

1

No helmet can protect wearer against all foreseeable high speed and low speed impacts.
However, for maximum head protection, the helmet must be of proper fit and retention system must be securely fastened under the chin. The helmet should allow peripheral vision when secure on your head. If your helmet is too large, it may sleep or move on your head while riding which may make it possible for your helmet to come off in an accident or to obstruct your vision while riding. In the first case, your helmet will not protect your head in an accident, which can result in serious personal injury or death and in the second case, if you cannot see you may have an accident.

2

Use only a helmet that fits snugly all around your head, and fasten the chinstrap securely under your chin.
Expand the helmet opening with your hands, and slide your head into the helmet. Please check whether the helmet fits properly according to the checklist (paragraph 3, page 3). Pull the chinstraps only, not the chinstraps covers. Pulling on the covers may rip them, if the helmet is not tight, it is too big for you, to securely fasten the D ring retention system, thread the end of the chinstrap through the D rings only as shown, and pull it tight up against your throat. In the case of quick-release retention system, refer to upper paragraph. If your chinstrap is loose, the shock of an impact may knock your helmet off leaving your head completely unprotected resulting in serious personal injury or death.

3

Helmets are designed to help absorb ONE impact. After your helmet has protected you from an impact, you must get a new one.
Your helmet is designed to distribute the force incurred during an impact over a wide area. Even if your helmet looks undamaged externally its useful life is finished after one impact during riding, for example, a capsize or accident where you and your helmet hit the ground or some object. In an impact, the helmet's impact absorbing liner becomes compacted. Once this has happened, the helmet no longer has the ability to absorb further impacts. Your helmet may look the same, but it will not provide protection in an accident. If you have any doubts, for example, if you drop your helmet or if it is hit by something and you are not sure if this one impact rule applies, consult your LS2 dealer before you use the helmet again.



4

Clean your helmet carefully.
Never use hot or salt water, benzene, gasoline, glass cleaner or other solvents. Your helmet could be seriously damaged by these substances, without showing any apparent visible damage. A helmet damaged or weakened by a cleaning agent may not provide head protection in an accident resulting in serious personal injury or death. The correct way to clean a helmet is to mix 5 or 6 drops of mild soap in a quart of warm water. Dampen a soft cloth with this solution and wipe the helmet clean. Rinse with a wet cloth.

5

Never modify your helmet.
It is very dangerous to drill holes or cut the shell and/or the shock absorber liner. Modifications can seriously weaken the helmet. Modifying the retention system weakens it, and it may snap in an impact, removing parts such as the mouth guard or rubber face trim can expose edges, which may injure you in an accident. Always use approved LS2 parts when replacing shields, screws, or any other parts. A weakened helmet will not provide protection.

6

Don't mistreat your helmet.
Never ride with the helmet hanging from the helmet holder, and don't hang the helmet from angled supports like a mirror. Don't sit on your helmet or throw it around. You should not expose the liner of your helmet to strong sunlight and excessive heat such as near heaters or where temperatures exceed 50° C (122 F). Avoid the spray of insect repellent chemicals (such as "naphthalene") near the helmet. Mistreating your helmet will damage the shell and impact absorbing liner and reduce the helmet's ability to protect you in an accident.

7

Always check your helmet before riding off.

1. Check the shield and visor screws, and retighten them if necessary.
2. Check for cracks in the helmet. Strong acid (for example, battery acid) can damage the shield base. If you find cracks or damage, stop using the helmet immediately.
3. Plastic components may start to wear out about 5 years after manufacture. If you find deterioration in any part of a component, either replace that component or get a new helmet. If these parts come loose and / or fall off while you are riding, your vision may be blocked which could cause an accident resulting in serious personal injury or death.
4. Check the security of the retention system
5. Make sure that the center pad (or comfort liner) and the cheek pads are attached before you use the helmet.



ENGLISH

İİDİÄÄÄ MT23030155

TYPE:
MX703



DATE : MAR. 2023
EXT. : 01
PAGE : 21/21

**R22.06/ECE TYPE-APPROVAL OF PROTECTIVE HELMETS AND THEIR VISORS FOR DRIVERS
AND PASSENGERS OF MOTORCYCLES AND MOPEDS**

USER INSTRUCTIONS (IV)

8

Maintain your helmet shield in good condition.

If your shield becomes too scratched or undeanable, replace it with a new one. Impaired visibility causes accidents. Clean your shield with mild soapy water, rinse well with clean water, and dry with a soft cloth. Never use benzene gasoline, glass cleaner or any other solvents. Do not attach stickers or adhesive tape to the shield, as this will weaken the hard coating. This can damage the shield. Do not drive with a dim or blurred face shield. Impaired vision can cause an accident resulting in serious personal injury or death.

9

Do not repaint the helmet.

We do not recommend you repaint the helmet, because paint and thinner can damage the materials used in the helmet construction. A helmet damaged weakened by a paint agent may not provide head protection in an accident resulting in serious personal injury or death. If you must paint your helmet, please consult your LS2 dealer.

10

Remember: helmets block important sounds and reduce awareness of environmental changes.

When you wear a helmet, especially a full-face type, you are somewhat isolated from the environment around you. Weather changes can catch you unprepared; sudden showers or temperature variations as you enter or leave tunnels or climb mountain roads can cause unexpected misting of your shield and loss of visibility. Do not drive with a fogged face shield. Wearing a helmet also reduces your ability to hear traffic sounds, especially of high speed. With a full face helmet, opening and closing the shield makes a major difference in how much you can hear. For safe riding be aware of how your helmet type, your speed, affects your perception of road conditions and whether your shield is open.



page 6