

BB14L-A2/12N14-3A

BS CODE: 310569

VOLTAGE **12V**

CCA **175A**

CAPACITY 20HR **14.7Ah**

CAPACITY 10HR **14.0Ah**



DIMENSIONS

LENGTH	134 ±2mm	5.28 ±0.08inch
WIDTH	89 ±2mm	3.5 ±0.08inch
TOTAL HEIGHT	166 ±2mm	6.54 ±0.08inch
WEIGHT	3.02 kg ±5%	6.66 lbs ±5%

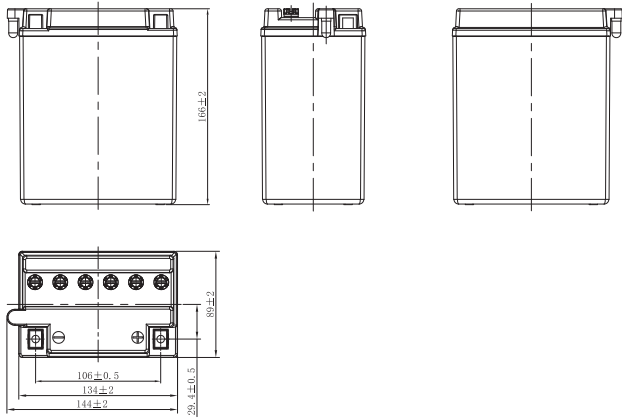

TERMINAL (mm)

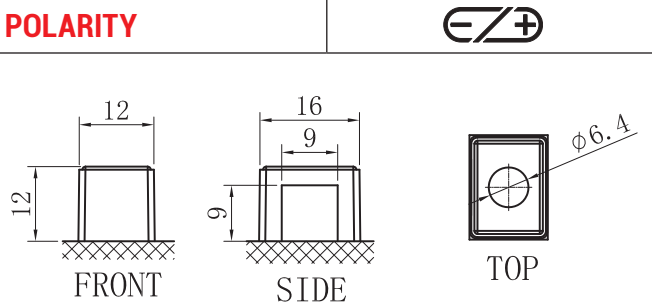

DRY FEATURES

- TO BE ACTIVATED**
DRY-charged technology.
- ACID PACK INCLUDED**
For initial filling.
- PERIODIC MAINTENANCE**
Refilled with water if necessary.
- HANDLE WITH CARE TO PREVENT ACID SPILLAGE**
- LONG SHELF LIFE**
No need to be recharged while stocked (if not activated).
- INTERNAL GAS EMISSION THROUGH VENTING HOLE**
- WIDE VARIETY OF 6V & 12V MODELS**

MOUNTING ANGLE

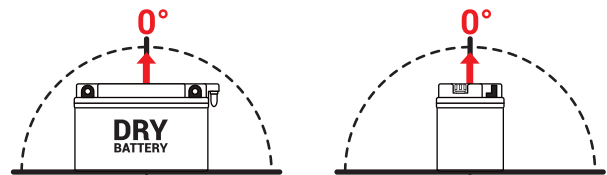

UPGRADE FOR

SLA MAX	SLA	MF	DRY
-	-	-	-