

DRY BATTERY

DRY | CONVENTIONAL

REF **U1-9**



12V VOLTAGE - V

220A CCA - A (EN)

24Ah CAPACITY - Ah (10Hr)

TECHNOLOGY

- Lead acid dry charged construction (absorbed acid)
- No acid in cells, must be filled with acid before use
- 6 & 12V batteries

FEATURES

- Upright installation only
- Has to be checked periodically and refilled with water if necessary
- Internal gas emission through venting hole
- Handle with care to prevent acid spillage
- Regular life duration
- Does not need to be recharged while stocked

UPGRADE FOR

WEIGHT

Battery (with acid) : Approx 7.47kg (16.45lbs)

MOUNTING ANGLE

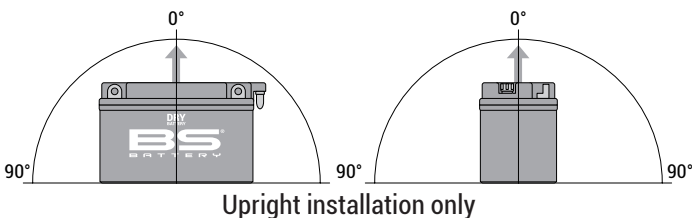

DIMENSIONS

Length (A) : 195±2mm (7.68in)
 Width (B) : 130±2mm (5.12in)
 Container height : 154±2mm (6.06in)
 Total height (C) : 180±2mm (7.09in)

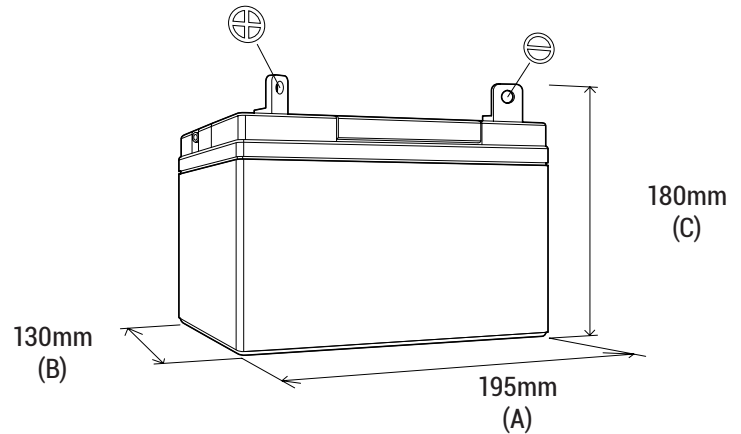

TERMINALS (mm)

